

**World Friendship Company, Ltd.**

**8712, 8725 Power Converter  
with Plastic Panel**

**Installation and Owners Manual**



Distributed in the US by CHENG USA, Inc.  
Sales (574) 294-8997  
Warranty Service (877)294-8997

## Installation of the WFCO 8700 Series Converter/Panel

- Select a mounting location near the shore power and battery
- Mount in such a way as to provide 2 to 3 inches on sides and top for adequate ventilation and maintain a 1 inch clearance from the floor to Allow the door to open. **Do not mount in an area where the owner May store items, this could effect the efficient operation of the converter.**
- **WARNING: DO NOT MOUNT THE CONVERTER IN A BATTERY OR AN LP GAS COMPARTMENT**
- Use only approve circuit breakers and ATC automotive type of fuses. Replace breakers and fuses with only the same size and Same manufacture.
- When routing around the converter be sure that all openings are protected from debris falling into the converter. **(this is a non-warranty situation)**
- If reverse polarity fuses have blown during installation check to see that the battery has been connected properly. Replace the fuse with only the same type and rating as the original. **Using other fuses could result in the converter being damaged, the vehicle being damaged, injury, or other consequences.**
- The WF-8700 Series Converter/Panel is not weather tight and not designed for mounting in wet locations, it must be protected from direct contact with water.



INSTALLATION INSTRUCTION

1



INSTALLATION INSTRUCTION

2

### TOP VIEW

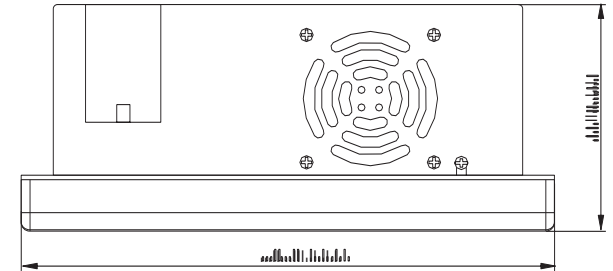

### REAR VIEW

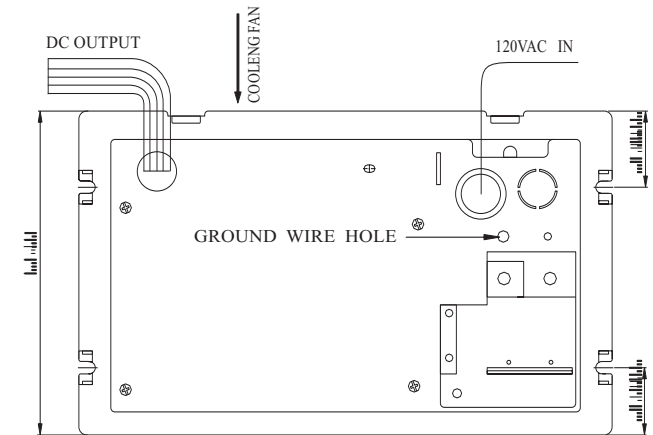

### BOTTOM VIEW

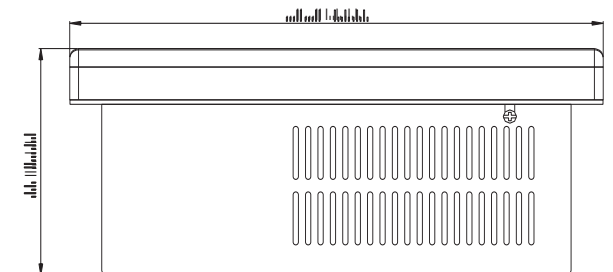

## General Information:

- **Reverse Battery protection:**

This feature prevents permanent damage from incorrect battery hookup.

- **Automatic Cooling Fan**

This will operate under high loads conditions normally not during sleeping hours or when power demands is low. Offering more sleeping comfort.

- **Electronic Current Limiting**

Automatically shuts down power during overload or short circuit conditions. Automatically returns to normal operation after conditions is corrected. No more hassle of replacing fuses, or resetting circuit breakers.

- **Durable Performance**

- Four 12 VDC circuit (one battery circuit)
- 120 VAC Main circuit and up two branch circuit
- **AC Breaker**

**The MAXIMUM Input Current is 30Amp 120VAC**

**AC Breaker Specification: Max 20 Amps 120V/240V 1pole or 2 poles.** Current interrupting rating MAX. RMS Sym. Amperes 10,000 at 120/240 Volt AC.

- **AC Breaker Manufacture:**

- Cutler Hammer Type BD2020, A2020
- Siemens type QP or QT
- Square D Type HOMT

- **Breaker Filler Plate:**

**FP-01(Brown Color)**

**FP-01B(Black Color)**

- **DC Fuse Information:**

- DC Fuse use only Littelfuse type 257 fuse, compliance UL 67
- WF-8712 : DC Fuse MAX. 15 Amp
- WF-8725 : DC Fuse MAX. 30 Amp



**INSTALLATION INSTRUCTION**

**3**



**INSTALLATION INSTRUCTION**

**4**

## FRONT VIEW

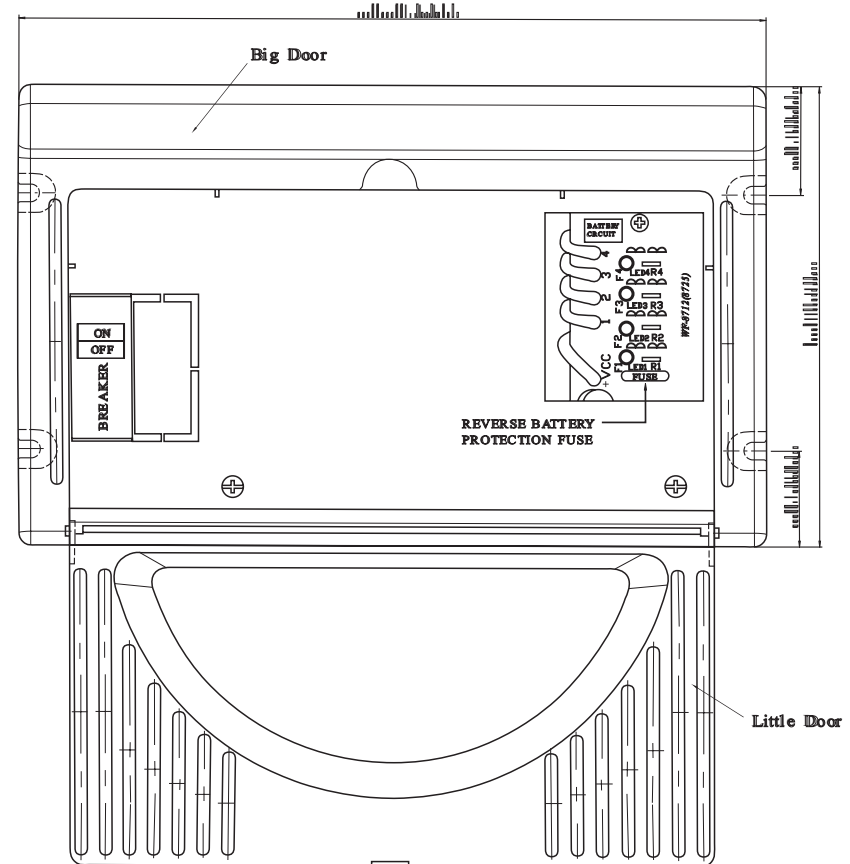



# INSTALLATION INSTRUCTION

5

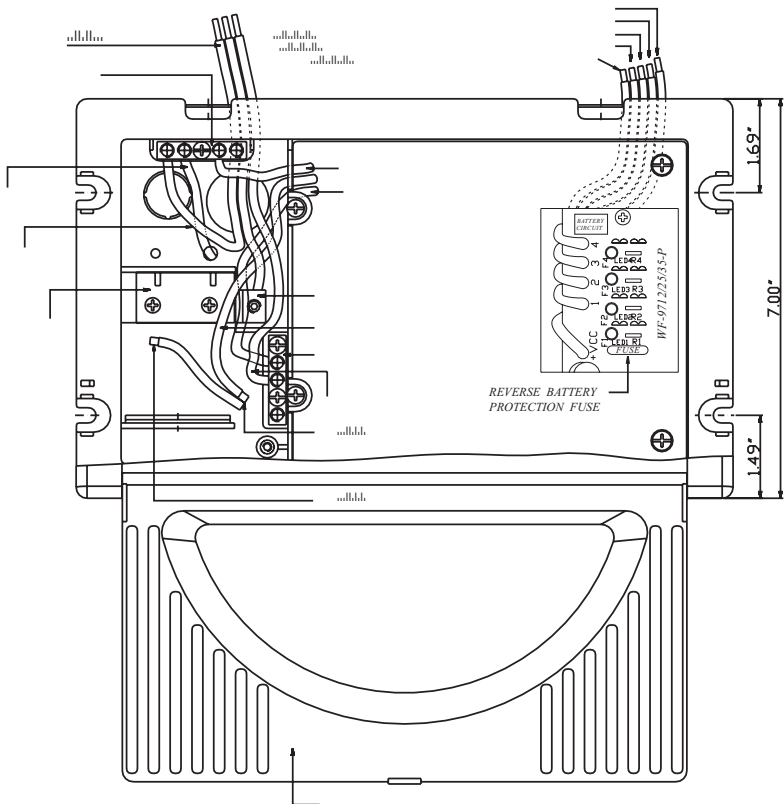

**Attention:**  
Do not exceed 30 IN-LB Torque on ground and neutral connections.



# INSTALLATION INSTRUCTION

6

If there is power to the converter then check the reverse polarity fuses on the front panel of the WF-9700 series power converters. First visually inspect the fuses for any breaks, if there are no breaks then use a continuity tester to test for continuity.

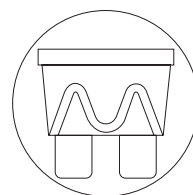

ATC FUSE

WF-8700 SERIES (12AMP, 25AMP)

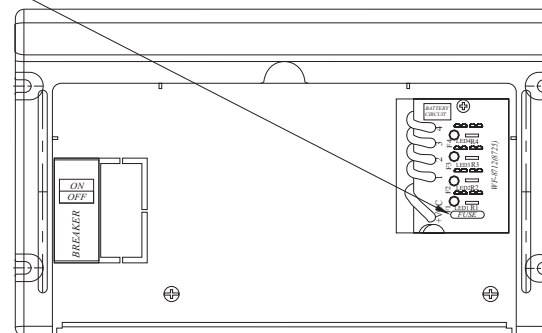

If fuse(s) are blown this means the RV Battery was accidentally connected in reverse either at the battery or at the converter. Connect properly then replace the fuse(s).

**IMPORTANT:** These fuses protect converter from damage in the event RV Battery is accidentally connected in reverse. A reverse battery connection even for a second is the only thing that will blow these fuses.

### Drawing 3

If converter output voltage reads 13.6 volts, but the battery is still not charging, check for an open automatic reset circuit breaker (if provided), or an open between the converter and distribution panel or an open wire between converter and RV Battery.

If the converter fuses check good and 120 V.A.C. and there is power at the outlet, but the converter output still reads zero volts, the converter is not functioning properly and must be replaced. For Warranty service contact WFCO at 1-877-294-8997. If the RV is out of warranty contact Cheng USA 1-877-294-8997.



The WFCO series of 3-stage switch mode power converter are fully automatic. The converter senses which mode it needs to be in by checking the condition of the batteries. The three modes include:

**Absorption Mode:** During this mode the converter output is at 13.6 VDC range. This is the mode that the converter will function at normally. This mode provides the 12 VDC and the current required by the RV.

**Bulk Mode:** When the converter senses that the battery voltage is less than 13.2 VDC the converter will automatically go into the Bulk Mode.

**Float Mode:** If the RV is not being used for a period of time and the shore power has been left plugged in, the converter will automatically go in to float mode. The converter senses if there has been any demand. If there is no activity for a period the converter will automatically go into float mode. When the converter senses a demand by turning on lights the converter automatically goes into buck mode and returns to absorption mode.



### Automatic Microprocessor Operation

Your WFCO power converter is equipped with a microcontroller mounted on the converter's PC board. The microcontroller is fully automatic and requires no additional equipment to operate. The microcontroller continuously monitors the battery condition and determines what mode the converter need to be in. Below are the function of the microcontroller.

- Our output voltage controlled microprocessor has been designed into the converter PC board to avoid the need for additional equipment when the power is initially applied to the power converter, the microcontroller cycles though its mode to determine which mode it needs.
- After the test cycle the power switches to Absorption mode (13.6VDC) when power is on.
- When the output of the power converter is connected to a battery and the load is applied (anything in the RV) the microcontroller checks to see which mode it need to be in.
- If the output voltage drops to 13.2VDC, the converter automatically changes to Bulk Mode 14.4VDC. Normally when the output voltage drops to 13.2VDC it means that the battery energy is less than 50%.
- Under Bulk Mode when the power converter senses that output voltage is at 14.4VDC. It will change back to absorption mode. This is important to battery durability and battery life.
- After a period of sensing no load the microprocessor automatically places the converter in Float mode 13.2VDC.
- The design of out microcontroller is to senses the battery voltage then make a decision to select the proper mode automatically.

### Storage Mode Status:

After a period of sensing no load or demand the microcontroller automatically places the converter into Float mode 13.2VDC



## GENERAL INFORMATION

The WF-8700 series power converters, 120VAC to 13.6VDC are intelligent, reliable electronic switch mode converter / battery chargers. The WF-8700 are UL,cUL (Canadian) listed. They comply with FCC Class B requirement (see below).

### FCC Compliance Class B:

NOTE: This equipment has been tested and found to comply with the limits for a Class B digital device, pursuant to Part 15 of the FCC Rules. These limits are designed to provide reasonable protection against harmful interference when the equipment is operated in a commercial environment. This equipment generates, uses, and can radiate radio frequency energy and, if not installed and used in accordance with the instruction manual, may cause harmful interference to radio communications. Operation of this equipment in a residential area is likely to cause harmful interference in which case the user will be required to correct the interference at his own expense.

**INSTALLATION INSTRUCTION**

**9**



**INSTALLATION INSTRUCTION**

**10**



## Consumer Limited Warranty For WFCO Electronic Products

WFCO extends, to the original owner a two year Limited Product Warranty. This Warranty is in effect from the date of original purchase for a period of two (2) years. This Limited Warranty is extended specifically for and is limited to recreational vehicle application and is only valid within the continental United States, Alaska, Hawaii and the provinces of Canada. WFCO warrants, to the owner, that its products are free from defects in material and workmanship under normal use and service based on its intended use and function. This Warranty is limited to the repair or replacement, at WFCO's discretion, of any defective parts or defective assembly. Any implied warranties of merchantability or fitness for intended use are limited in duration unless applicable State Law provides otherwise. You may have other rights as specified by each individual state.

### EXCLUSIONS and LIMITATION

The OEM warranty specifically does not apply to the following:  
Any WFCO product that has been repaired or altered by any unauthorized person;  
Any damage caused by misuse, faulty installation, testing, negligence or accident or any WFCO product installed in a commercial vehicle;  
Any WFCO product whose serial number has been defaced, altered or removed;  
Any WFCO product whose installation has not been in accordance to WFCO written instructions;  
Any consequential damages arising from the loss of use of the product including but not limited to: inconvenience, loss of service, loss of revenue, loss or damage to personal property and cost of all services performed in removing or replacing the WFCO product;

### CONSUMER WARRANTY CLAIM PROCEDURE

Upon determination and validation by an authorized OEM dealer that a WFCO product has a defect, the dealer shall contact the WFCO warranty service number (877) 294-8997 and obtain a return goods authorization (RGA) number. This number shall appear on all correspondence with warranty service, Upon validation of the warranty WFCO shall replace or repair the product with a like product. The RGA number must also be placed on the outside of the carton used to return the product for ease of identification. Do not mark directly on the product. The product must be packaged properly to avoid further damage to the product to cause a non-warrantable condition.